

Load Rating Chart

Model 50128S

Manitex

© Manitex 2000

NOTE: Additional copies of this Load Rating Chart can be purchased from your Manitex Distributor. When ordering, use the part number shown in the bottom left corner of this page.

LMI OPERATING CODES

CODE	CRANE CONFIGURATION	OUTRIGGER CONFIGURATION	AREA OF OPERATION
#1	MAIN BOOM	FULLY EXTENDED	OVER REAR
#3	MAIN BOOM	FULLY EXTENDED	FULL 360°
#4	MAIN BOOM	MID POSITION	FULL 360°
#5	MAIN BOOM	RETRACTED	FULL 360°
#7	RETRACTED JIB 0° OFFSET	FULLY EXTENDED	OVER REAR
#8	RETRACTED JIB 0° OFFSET	FULLY EXTENDED	FULL 360°
#9	RETRACTED JIB 15° OFFSET	FULLY EXTENDED	OVER REAR
#10	RETRACTED JIB 15° OFFSET	FULLY EXTENDED	FULL 360°
#11	RETRACTED JIB 30° OFFSET	FULLY EXTENDED	OVER REAR
#12	RETRACTED JIB 30° OFFSET	FULLY EXTENDED	FULL 360°
#13	EXTENDED JIB 0° OFFSET	FULLY EXTENDED	OVER REAR
#14	EXTENDED JIB 0° OFFSET	FULLY EXTENDED	FULL 360°
#15	EXTENDED JIB 15° OFFSET	FULLY EXTENDED	OVER REAR
#16	EXTENDED JIB 15° OFFSET	FULLY EXTENDED	FULL 360°
#17	EXTENDED JIB 30° OFFSET	FULLY EXTENDED	OVER REAR
#18	EXTENDED JIB 30° OFFSET	FULLY EXTENDED	FULL 360°
#19	RETRACTED JIB 0° OFFSET	MID POSITION	FULL 360°
#20	RETRACTED JIB 15° OFFSET	MID POSITION	FULL 360°
#21	RETRACTED JIB 30° OFFSET	MID POSITION	FULL 360°
#22	EXTENDED JIB 0° OFFSET	MID POSITION	FULL 360°
#23	EXTENDED JIB 15° OFFSET	MID POSITION	FULL 360°
#24	EXTENDED JIB 30° OFFSET	MID POSITION	FULL 360°
#25	PERSONNEL LIFTING MAIN BOOM	FULLY EXTENDED	FULL 360°
#26	PERSONNEL LIFTING RETR JIB 0° OFFSET	FULLY EXTENDED	FULL 360°
#27	PERSONNEL LIFTING RETR JIB 15° OFFSET	FULLY EXTENDED	FULL 360°
#28	PERSONNEL LIFTING RETR JIB 30° OFFSET	FULLY EXTENDED	FULL 360°
#29	PERSONNEL LIFTING EXTENDED JIB 0° OFFSET	FULLY EXTENDED	FULL 360°
#30	PERSONNEL LIFTING EXTENDED JIB 15° OFFSET	FULLY EXTENDED	FULL 360°
#31	PERSONNEL LIFTING EXTENDED JIB 30° OFFSET	FULLY EXTENDED	FULL 360°

WARNING

1. THE OPERATOR MUST READ AND UNDERSTAND THE OWNER'S MANUAL BEFORE OPERATING THIS CRANE.

2. POSITIONING OR OPERATION OF CRANE BEYOND AREAS SHOWN ON THIS CHART IS NOT INTENDED OR APPROVED EXCEPT WHERE SPECIFIED IN OWNER'S MANUAL.

3. LOADED BOOM ANGLES AT SPECIFIED BOOM LENGTHS GIVE ONLY AN APPROXIMATION OF THE OPERATING RADIUS. THE BOOM ANGLE BEFORE LOADING SHOULD BE GREATER TO ACCOUNT FOR DEFLECTIONS. DO NOT EXCEED THE OPERATING RADIUS FOR RATED LOADS.

4. THE OPERATING RADIUS SHOWN IN THE JIB RATING CHART IS FOR FULLY EXTENDED BOOM ONLY. WHEN BOOM IS NOT FULLY EXTENDED, USE ONLY LOADED BOOM ANGLE TO DETERMINE LOAD RATING OF JIB.

5. FOR BOOM ANGLES NOT SHOWN ON JIB LOAD RATING CHART, USE RATING OF NEXT LOWER BOOM ANGLE.

WARNING (CONTINUED)





6. FOR BOOM LENGTHS NOT SHOWN, USE RATING OF NEXT SHORTER OR LONGER BOOM LENGTH, WHICHEVER IS LESS. FOR RADII NOT SHOWN, USE RATING OF NEXT LONGER RADIUS.
7. CRANE LOAD RATINGS ON OUTRIGGERS ARE BASED ON FREELY SUSPENDED LOADS WITH THE MACHINE LEVELED AND STANDING ON A FIRM UNIFORM SUPPORTING SURFACE. NO ATTEMPT SHALL BE MADE TO MOVE A LOAD HORIZONTALLY ON THE GROUND IN ANY DIRECTION.
8. PRACTICAL WORKING LOADS DEPEND ON SUPPORTING SURFACE, WIND, AND OTHER FACTORS AFFECTING STABILITY SUCH AS HAZARDOUS SURROUNDINGS, EXPERIENCE OF PERSONNEL, AND PROPER HANDLING, ALL OF WHICH MUST BE TAKEN INTO ACCOUNT BY THE OPERATOR.
9. THE MAXIMUM LOAD WHICH MAY BE TELESCOPED IS LIMITED BY HYDRAULIC PRESSURE, BOOM ANGLE, AND BOOM LUBRICATION. IT IS SAFE TO ATTEMPT TO TELESCOPE ANY LOAD WITHIN THE LIMITS OF THE LOAD RATING CHART.

INFORMATION

1. DEDUCTIONS MUST BE MADE FROM RATED LOADS FOR JIB, OPTIONAL ATTACHMENTS, HOOKS, AND LOADBLOCKS (SEE DEDUCTION CHART). WEIGHTS OF SLINGS AND ALL OTHER LOAD HANDLING DEVICES SHALL BE CONSIDERED A PART OF THE LOAD.
2. LOAD RATINGS ABOVE THE HEAVY LINE ARE STRUCTURALLY LIMITED CAPACITIES. LOAD RATINGS BELOW THE HEAVY LINE ARE STABILITY LIMITED CAPACITIES AND DO NOT EXCEED 85% OF TIPPING.

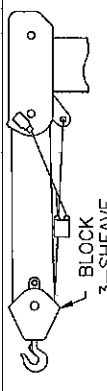
DEFINITIONS

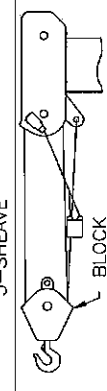
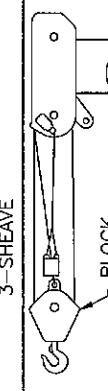
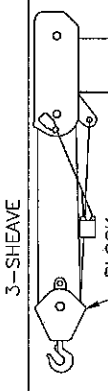
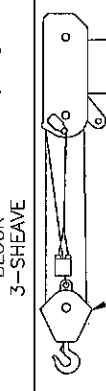
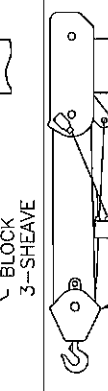
1. OPERATING RADIUS IS THE HORIZONTAL DISTANCE FROM THE AXIS OF ROTATION TO THE CENTER OF THE VERTICAL HOIST LINE OR TACKLE WITH LOAD APPLIED.
2. LOADED BOOM ANGLE IS THE INCLUDED ANGLE BETWEEN THE HORIZONTAL AND LONGITUDINAL AXES OF THE BOOM BASE AFTER LIFTING RATED LOAD AT RATED RADIUS.

ALLOWABLE LINE PULL										WARNING
1 PART LINE	2 PART LINE	3 PART LINE	4 PART LINE	5 PART LINE	6 PART LINE	7 PART LINE	8 PART LINE	9 PART LINE	10 PART LINE	
										ANTI-TWO-BLOCK SYSTEM MUST BE IN GOOD OPERATING CONDITION BEFORE OPERATING CRANE. REFER TO THE OWNER'S MANUAL. KEEP AT LEAST 3 WRAPS OF LOAD LINE ON THE DRUM AT ALL TIMES.
10000 LBS	20000 LBS	30000 LBS	40000 LBS	50000 LBS	60000 LBS	70000 LBS	80000 LBS	90000 LBS	100000 LBS	5/8" 6 X 19 CLASS (3.5:1 SF) 35,000 LBS MIN BREAKING STRENGTH 5/8" ROT RESISTANT (5:1 SF) 50,000 LBS MIN BREAKING STRENGTH

AREA OF OPERATIONS

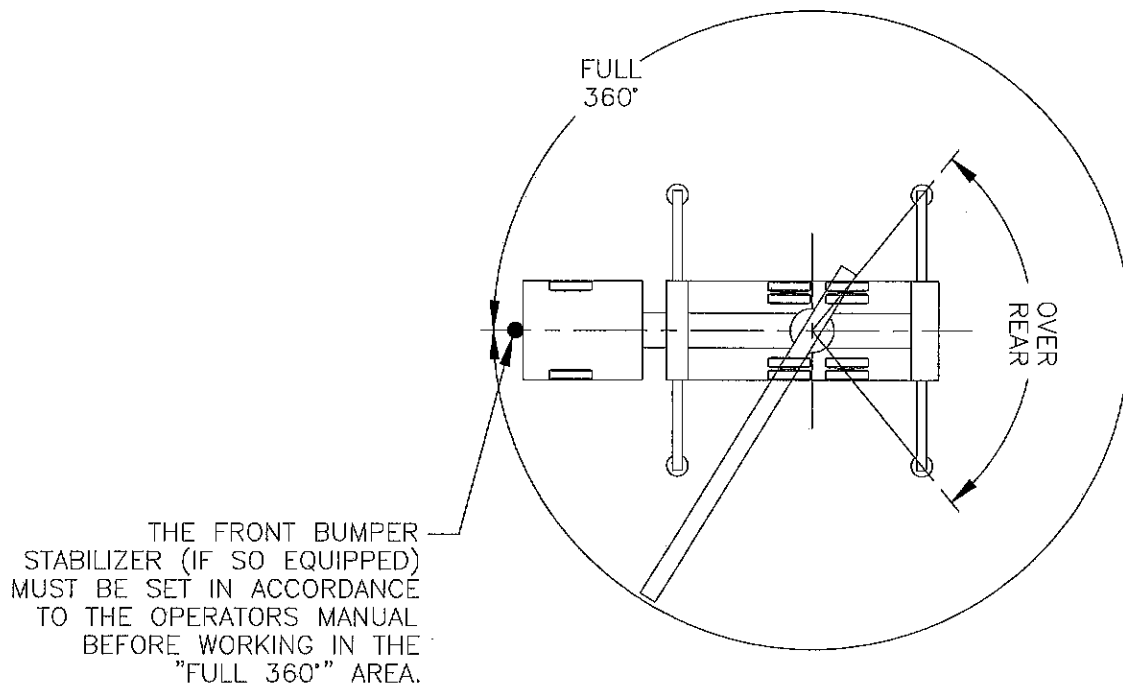

DEDUCTIONS FROM RATED LOADS FOR LOAD HANDLING DEVICES SUPPLIED BY MANITEX

AUXILIARY BLOCK	-----	50 LBS
ROOSTER SHEAVE	-----	70 LBS
LIFTING FROM MAIN BOOM WITH JIB STOWED OR ERECTED	-----	SEE LOAD CHART
OVERHAUL BALL	-----	SEE MANUFACTURER NAMEPLATE
LOAD BLOCK	-----	SEE MANUFACTURER NAMEPLATE

- RANGE DIAGRAM -

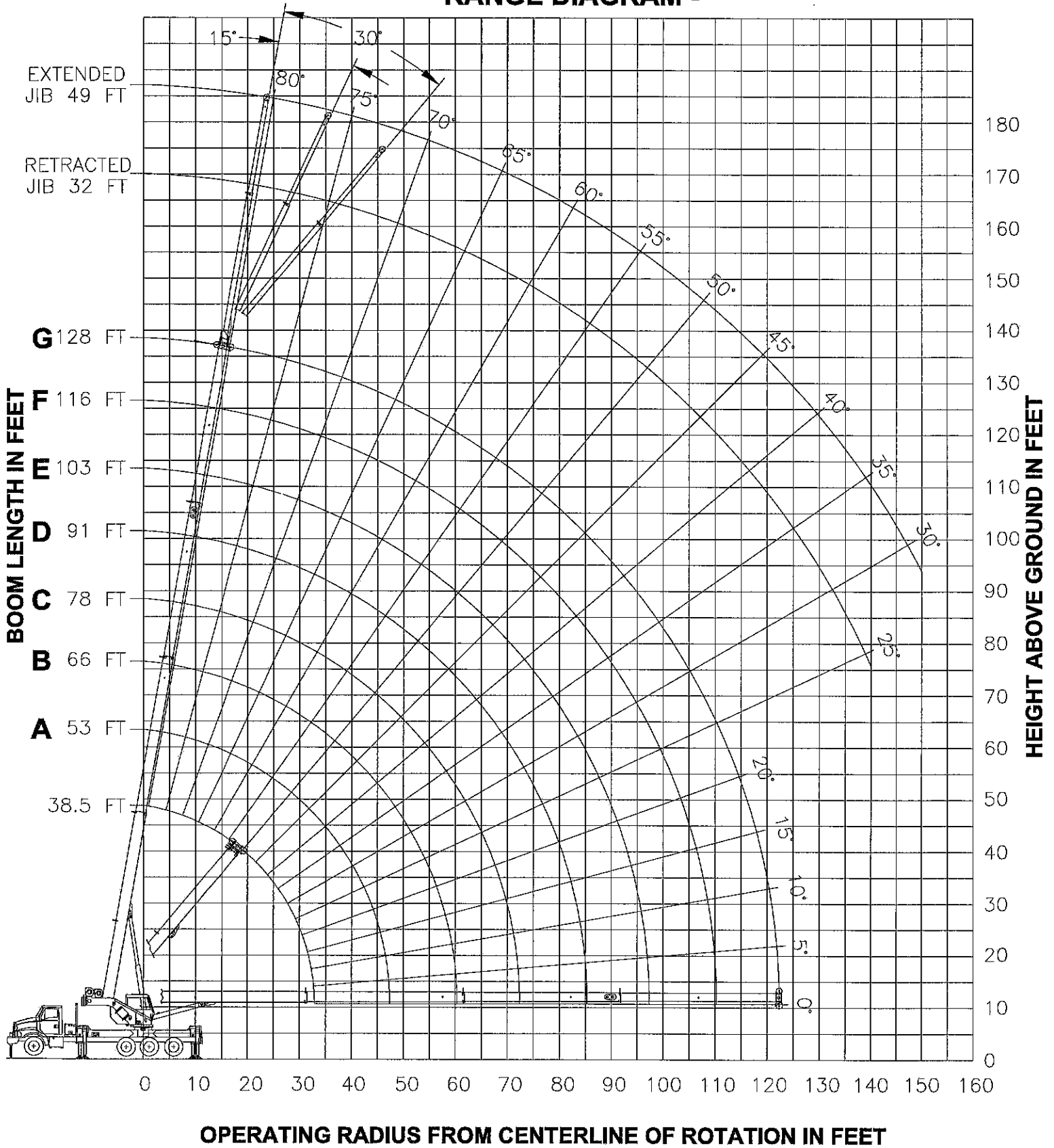

**USE THIS CHART ONLY
WHEN ALL OUTRIGGER
BEAMS ARE FULLY
EXTENDED**

PINS MUST BE
DISENGAGED FOR
THIS OUTRIGGER
CONFIGURATION

OUTRIGGER
BEAMS MUST
BE EXTENDED
TO MARK

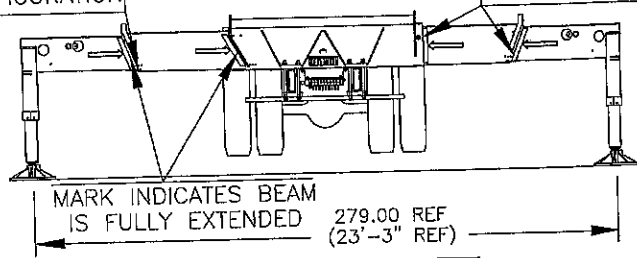

MAIN BOOM LIFTING CAPACITIES

LOAD RADIUS (FT)	BOOM LENGTH 38.5 FT			BOOM LENGTH 53 FT (A)			BOOM LENGTH 66 FT (B)			BOOM LENGTH 78 FT (C)			LOAD RADIUS (FT)		
	LOADED BOOM ANGLE (DEG)	CODE 1	CODE 3	LOADED BOOM ANGLE (DEG)	CODE 1	CODE 3	LOADED BOOM ANGLE (DEG)	CODE 1	CODE 3	LOADED BOOM ANGLE (DEG)	CODE 1	CODE 3			
		OVER REAR (LBS)	FULL 360° (LBS)		OVER REAR (LBS)	FULL 360° (LBS)		OVER REAR (LBS)	FULL 360° (LBS)		OVER REAR (LBS)	FULL 360° (LBS)		OVER REAR (LBS)	FULL 360° (LBS)
6	73.5	100000	100000										6		
8	70.5	86600	86600										8		
10	67	76400	76400	74.5	51000	51000	78	51000	51000				10		
12	64	68400	68400	72.5	51000	51000	76.5	51000	51000	79	41710	41710	12		
15	59	59000	59000	68.5	51000	51000	73.5	46650	46650	77	37880	37880	15		
20	49.5	47670	47670	62.5	45700	45700	69	39300	39300	73	32140	32140	20		
25	38.5	36900	36900	56	37680	37680	64	33450	33450	69	27890	27890	25		
30	23.5	29590	27090	49.5	30410	28290	59	29140	28850	65	24230	24230	30		
35				41.5	25170	20960	54	25490	21480	61	21310	21310	35		
40				32	21200	16200	48	21590	16700	56.5	19160	16990	40		
45				18.5	18060	12830	42	18490	13350	52	17070	13630	45		
50							34.5	16000	10860	46.5	15330	11140	50		
55							25	13940	8930	41	13850	9220	55		
60							7	9790	7350	35	12440	7690	60		
65										27	10830	6440	65		
70										16	9430	5390	70		
												STOWED JIB			
												ERECTED JIB (RETRACTED)			
												ERECTED JIB (EXTENDED)			
			1230 LBS				890 LBS				720 LBS				610 LBS
			2840 LBS				2620 LBS				2500 LBS				2430 LBS
			3170 LBS				2860 LBS				2700 LBS				2600 LBS

DEDUCTIONS FOR MAIN BOOM CAPACITIES

LOAD RADIUS (FT)	BOOM LENGTH 91 FT (D)			BOOM LENGTH 103 FT (E)			BOOM LENGTH 116 FT (F)			BOOM LENGTH 120 FT (G)			LOAD RADIUS (FT)		
	LOADED BOOM ANGLE (DEG)	CODE 1	CODE 3	LOADED BOOM ANGLE (DEG)	CODE 1	CODE 3	LOADED BOOM ANGLE (DEG)	CODE 1	CODE 3	LOADED BOOM ANGLE (DEG)	CODE 1	CODE 3			
		OVER REAR (LBS)	FULL 360° (LBS)		OVER REAR (LBS)	FULL 360° (LBS)		OVER REAR (LBS)	FULL 360° (LBS)		OVER REAR (LBS)	FULL 360° (LBS)		OVER REAR (LBS)	FULL 360° (LBS)
15	79	30000	30000										15		
20	76	26010	26010	78.5	22790	22790							20		
25	72.5	22620	22620	75.5	20160	20160	78	17660	17660				25		
30	69.5	20000	20000	72.5	18080	18080	75.5	16060	16060	77.5	13000	13000	30		
35	66	17710	17710	70.5	16070	16070	73	14480	14480	75.5	12760	12760	35		
40	62.5	15740	15740	67.5	14360	14360	70.5	13050	13050	73	11760	11760	40		
45	59	14050	13840	64	12900	12900	68	11780	11780	71	10800	10800	45		
50	55	12620	11340	60.5	11610	11480	65	10640	10640	68.5	10000	10000	50		
55	50.5	11380	9420	57	10500	9550	62	9890	9660	66	9130	9130	55		
60	46.5	10340	7890	53.5	9760	8020	59	8970	8130	63.5	8320	8200	60		
65	41.5	9630	6650	50	8860	6780	56	8160	6880	60.5	7570	6950	65		
70	36.5	8770	5610	46	8060	5740	53	7430	5850	58	6910	5920	70		
75	30	8000	4740	41.5	7350	4870	49.5	6780	4970	55	6300	5050	75		
80	22	7320	3980	37	6720	4120	46	6180	4230	52	5750	4300	80		
85	7	5290	3300	31.5	6140	3480	42.5	5650	3580	49	5250	3650	85		
90				25	5630	2910	38	5160	3020	46	4790	3090	90		
95				15.5	5160	2390	33.5	4720	2520	42	4370	2590	95		
100							28.5	4310	2070	38.5	3980	2150	100		
105							21.5	3940	1670	34	3620	1760	105		
110							7.5	3610	1290	29.5	3300	1400	110		
115										23.5	2990	1070	115		
120										15	2710	770	120		
												STOWED JIB			
												ERECTED JIB (RETRACTED)			
												ERECTED JIB (EXTENDED)			
			520 LBS				460 LBS				410 LBS				370 LBS
			2370 LBS				2330 LBS				2300 LBS				2280 LBS
			2520 LBS				2460 LBS				2410 LBS				2380 LBS

DEDUCTIONS FOR MAIN BOOM CAPACITIES

**USE THIS CHART ONLY
WHEN ALL OUTRIGGER
BEAMS ARE IN THE MID
POSITION**

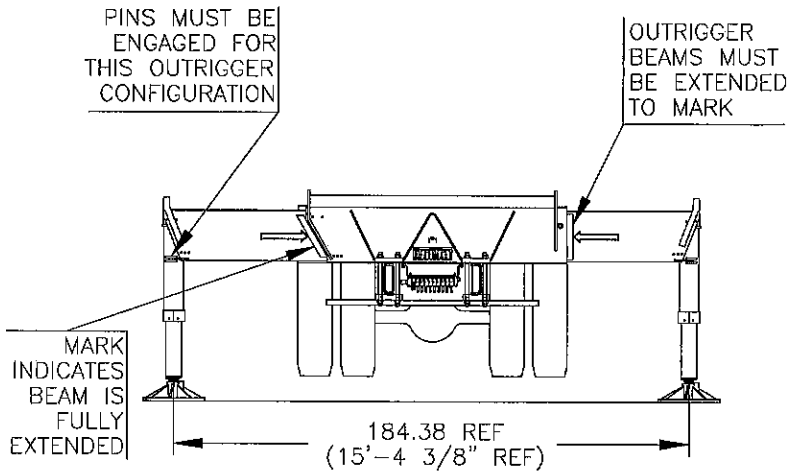

MAIN BOOM LIFTING CAPACITIES

LMI CODE 4																	
LOAD RADIUS (FT)	BOOM LENGTH 38.5 FT		BOOM LENGTH 53 FT (A)		BOOM LENGTH 66 FT (B)		BOOM LENGTH 78 FT (C)		BOOM LENGTH 91 FT (D)		BOOM LENGTH 103 FT (E)		BOOM LENGTH 116 FT (F)		BOOM LENGTH 128 FT (G)		LOAD RADIUS (FT)
	LOADED BOOM ANGLE (DEG)	FULL 360° (LBS)	LOADED BOOM ANGLE (DEG)	FULL 360° (LBS)	LOADED BOOM ANGLE (DEG)	FULL 360° (LBS)	LOADED BOOM ANGLE (DEG)	FULL 360° (LBS)	LOADED BOOM ANGLE (DEG)	FULL 360° (LBS)	LOADED BOOM ANGLE (DEG)	FULL 360° (LBS)	LOADED BOOM ANGLE (DEG)	FULL 360° (LBS)	LOADED BOOM ANGLE (DEG)	FULL 360° (LBS)	
6	73.5	100000															6
8	70.5	86600															8
10	67	76400	74.5	51000	78	51000											10
12	64	68400	72.5	51000	76.5	51000	79	41710									12
15	59	50190	68.5	51000	73.5	46650	77	37880	79	30000							15
20	49.5	27120	62.5	28220	69	28790	73	29140	76	26010	78.5	22790					20
25	38.5	17330	56	18320	64	18800	69	19100	72.5	19340	75.5	19500	78	17600			25
30	23.5	11870	49.5	12840	59	13290	65	13560	69.5	13770	72.5	13910	75.5	14040	77.5	13000	30
35			41.5	9360	54	9790	61	10040	66	10240	70.5	10370	73	10490	75.5	10570	35
40			32	6930	48	7360	56.5	7610	62.5	7800	67.5	7930	70.5	8030	73	8110	40
45			18.5	5120	42	5580	52	5830	59	6010	64	6130	68	6230	71	6310	45
50					34.5	4220	46.5	4470	55	4640	60.5	4760	65	4860	68.5	4930	50
55					25	3120	41	3380	50.5	3560	57	3680	62	3780	66	3840	55
60					17	2200	35	2510	46.5	2690	53.5	2810	59	2900	63.5	2970	60
65							27	1770	41.5	1960	50	2080	56	2170	60.5	2240	65
70							16	1140	36.5	1350	46	1470	53	1560	58	1630	70
75									30	830	41.5	950	49.5	1040	55	1110	75
80																	80
85																	85

DEDUCTIONS FOR JIB FROM MAIN BOOM CAPACITIES								
1230 LBS	890 LBS	720 LBS	610 LBS	520 LBS	460 LBS	410 LBS	370 LBS	STOWED
2840 LBS	2620 LBS	2500 LBS	2430 LBS	2370 LBS	2330 LBS	2300 LBS	2280 LBS	RETR
3170 LBS	2860 LBS	2700 LBS	2600 LBS	2520 LBS	2460 LBS	2410 LBS	2380 LBS	EXTEND

**USE THIS CHART WHEN ALL
OUTRIGGER BEAMS ARE NOT IN
EITHER THE MID OR FULLY
EXTENDED POSITION**

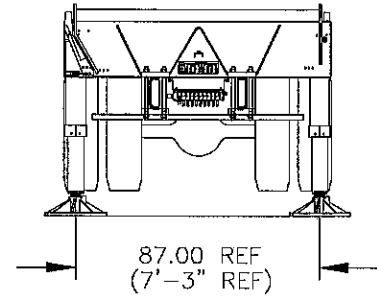

MAIN BOOM LIFTING CAPACITIES

LMI CODE 5													
LOAD RADIUS (FT)	BOOM LENGTH 38.5 FT		BOOM LENGTH 53 FT (A)		BOOM LENGTH 66 FT (B)		BOOM LENGTH 78 FT (C)		BOOM LENGTH 91 FT (D)		BOOM LENGTH 103 FT (E)		LOAD RADIUS (FT)
	LOADED BOOM ANGLE (DEG)	FULL 360° (LBS)	LOADED BOOM ANGLE (DEG)	FULL 360° (LBS)	LOADED BOOM ANGLE (DEG)	FULL 360° (LBS)	LOADED BOOM ANGLE (DEG)	FULL 360° (LBS)	LOADED BOOM ANGLE (DEG)	FULL 360° (LBS)	LOADED BOOM ANGLE (DEG)	FULL 360° (LBS)	
6	73.5	93380											6
8	70.5	47730											8
10	67	30710	74.5	31930	78	32570							10
12	64	21810	72.5	22870	76.5	23420	79	23770					12
15	59	14330	68.5	15250	73.5	15730	77	16020	79	16260			15
20	49.5	7920	62.5	8750	69	9160	73	9420	76	9620	78.5	9760	20
25	38.5	4480	56	5280	64	5670	69	5900	72.5	6080	75.5	6210	25
30	23.5	2300	49.5	3120	59	3490	65	3720	69.5	3890	72.5	4000	30
35			41.5	1630	54	2000	61	2220	66	2390	70.5	2500	35
40					48	920	56.5	1140	62.5	1300	67.5	1410	40
45													45
50													50
DEDUCTIONS FOR STOWED JIB FROM MAIN BOOM CAPACITIES													
	1230 LBS		890 LBS		720 LBS		610 LBS		520 LBS		460 LBS		

WARNINGS

1. THE JIB MUST BE IN THE STOWED POSITION, IF SO EQUIPPED, WHEN USING THIS OUTRIGGER CONFIGURATION.
2. DO NOT EXCEED A BOOM LENGTH OF 103 FEET WITH THIS OUTRIGGER CONFIGURATION.

**USE THIS CHART ONLY
WHEN ALL OUTRIGGER
BEAMS ARE FULLY
EXTENDED**

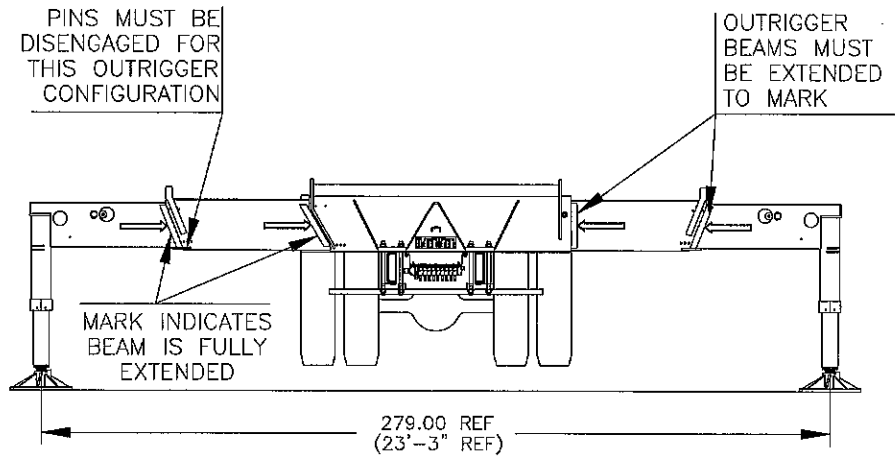

32 FT RETRACTED JIB LIFTING CAPACITIES

LOAD RADIUS (FT)	LOADED BOOM ANGLE (DEG)	0' OFFSET		15' OFFSET			30' OFFSET		
		CODE 7 OVER REAR (LBS)	CODE 8 FULL 360° (LBS)	LOADED BOOM ANGLE (DEG)	CODE 9 OVER REAR (LBS)	CODE 10 FULL 360° (LBS)	LOADED BOOM ANGLE (DEG)	CODE 11 OVER REAR (LBS)	CODE 12 FULL 360° (LBS)
35	78	5400	5400						
40	76.5	5400	5400	79.5	5400	5400			
45	75	5400	5400	78	5400	5400			
50	73.5	5400	5400	76.5	5400	5400	79	5400	5400
55	72	5400	5400	74.5	5400	5400	77	5400	5400
60	70	5400	5400	73	5400	5400	75	5400	5400
65	68.5	5400	5400	71	5400	5400	73	5240	5240
70	66.5	5210	5210	69	5230	5230	71.5	4990	4990
75	64.5	4740	4740	67	4970	4970	69.5	4750	4750
80	62.5	4300	4140	65	4570	4570	67.5	4520	4520
85	60.5	3890	3490	63	4140	3890	65	4310	4220
90	58	3510	2920	61	3740	3280	63	3930	3580
95	55.5	3160	2410	58.5	3360	2740	60.5	3540	3010
100	53	2820	1970	56	3010	2270	58	3170	2500
105	50.5	2520	1570	53.5	2690	1840	55.5	2830	2040
110	48	2230	1210	50.5	2390	1450	52.5	2510	1630
115	45.5	1960	880	48	2100	1100	49.5	2210	1260
120	42.5	1700		45	1830		46.5	1920	910
125	39.5	1470		42	1580		43	1660	
130	36.5	1240		38.5	1350		39.5	1400	
135	32.5	1030		34.5	1120		35.5	1160	
140	28.5	840		30.5	910		30.5	920	
145									

**USE THIS CHART ONLY
WHEN ALL OUTRIGGER
BEAMS ARE FULLY
EXTENDED**

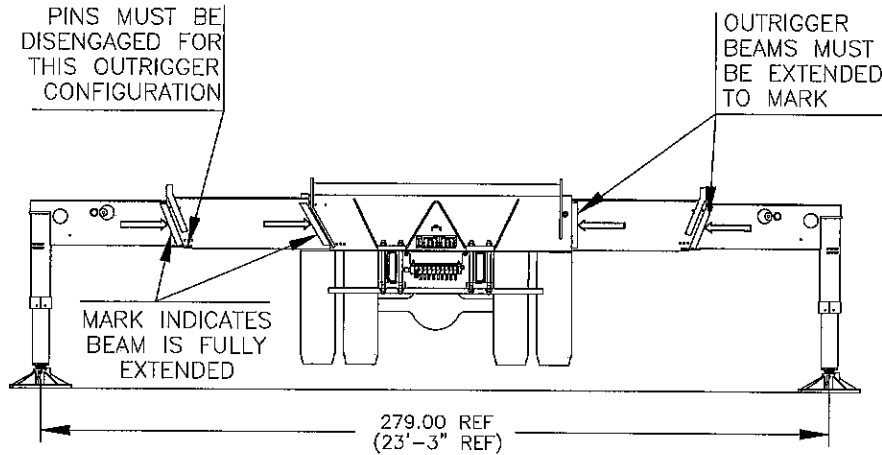

49 FT EXTENDED JIB LIFTING CAPACITIES

LOAD RADIUS (FT)	LOADED BOOM ANGLE (DEG)	0' OFFSET		15' OFFSET			30' OFFSET		
		CODE 13	CODE 14	LOADED BOOM ANGLE (DEG)	CODE 15	CODE 16	LOADED BOOM ANGLE (DEG)	CODE 17	CODE 18
		OVER REAR (LBS)	FULL 360° (LBS)		OVER REAR (LBS)	FULL 360° (LBS)		OVER REAR (LBS)	FULL 360° (LBS)
40	78	4300	4300						
45	76.5	4300	4300						
50	75	4300	4300	79.5	4300	4300			
55	73.5	4300	4300	78	4300	4300			
60	72	4300	4300	76.5	4300	4300	79.5	3700	3700
65	70.5	4300	4300	75	4300	4300	78	3590	3590
70	69	4300	4300	73.5	4230	4230	76	3490	3490
75	67.5	4300	4300	71.5	4080	4080	74	3390	3390
80	66	4240	4240	70	3930	3930	72.5	3300	3300
85	64.5	4030	4030	68.5	3760	3760	70.5	3220	3220
90	63	3740	3530	66.5	3590	3590	69	3140	3140
95	61	3430	3020	64.5	3420	3420	67	3070	3070
100	59	3120	2560	62.5	3270	3030	65	3000	3000
105	57	2840	2160	60.5	3100	2590	63	2940	2940
110	54.5	2560	1800	58	2810	2190	61	2880	2520
115	52	2310	1470	56	2540	1830	58.5	2720	2120
120	49.5	2070	1170	53.5	2280	1500	56	2450	1760
125	47	1840	900	51	2040	1200	53.5	2190	1430
130	44.5	1630		48	1810	920	50.5	1940	1120
135	42	1430		45.5	1590		47.5	1700	830
140	39.5	1240		42.5	1390		44.5	1480	
145	36.5	1060		39.5	1190		41	1260	
150	33	900		36	1000		37	1050	
155				32	820		32.5	850	
160									

**USE THIS CHART ONLY
WHEN ALL OUTRIGGER
BEAMS ARE IN THE MID
POSITION**

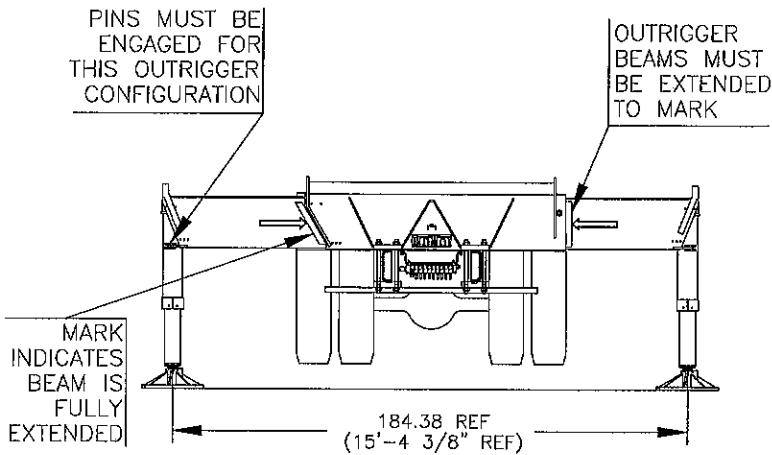

32 FT RETRACTED JIB LIFTING CAPACITIES

LOAD RADIUS (FT)	0° OFFSET		15° OFFSET		30° OFFSET	
	LOADED BOOM ANGLE (DEG)	CODE 19 FULL 360° (LBS)	LOADED BOOM ANGLE (DEG)	CODE 20 FULL 360° (LBS)	LOADED BOOM ANGLE (DEG)	CODE 21 FULL 360° (LBS)
35	78	5400				
40	76.5	5400	79.5	5400		
45	75	5400	78	5400		
50	73.5	4740	76.5	5400	79	5400
55	72	3630	74.5	4310	77	4910
60	70	2740	73	3350	75	3870
65	68.5	2000	71	2540	73	3010
70	66.5	1380	69	1870	71.5	2280
75	64.5	860	67	1300	69.5	1660
80					67.5	1130
85						

49 FT EXTENDED JIB LIFTING CAPACITIES

LOAD RADIUS (FT)	0° OFFSET		15° OFFSET		30° OFFSET	
	LOADED BOOM ANGLE (DEG)	CODE 22 FULL 360° (LBS)	LOADED BOOM ANGLE (DEG)	CODE 23 FULL 360° (LBS)	LOADED BOOM ANGLE (DEG)	CODE 24 FULL 360° (LBS)
40	78	4300				
45	76.5	4300				
50	75	4300	79.5	4300		
55	73.5	4300	78	4300		
60	72	3390	76.5	4280	79.5	3700
65	70.5	2640	75	3440	78	3590
70	69	2010	73.5	2740	76	3380
75	67.5	1470	71.5	2130	74	2710
80	66	1010	70	1610	72.5	2140
85			68.5	1160	70.5	1630
90			66.5	760	69	1190
95					67	800
100						